

- (A) Zastavbovy rozmer / In-built dimension / Baumaße
- (B) Litinový odvod kouře / Cast iron spigot / Der gusseiserne Rauchabgang
- (C) Centralní privod vzduchu / Central air inlet / Zentralluftzufuhr
- (D) Primární a sekundární vzduch / Primary and secondary air / Primärluft und Sekundärluft
- (L) Volná plocha prosklení / Free glass area / Freie Glassichtfläche

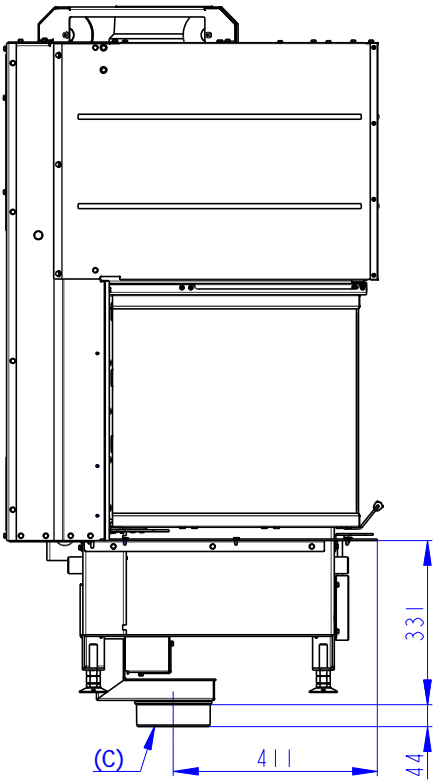

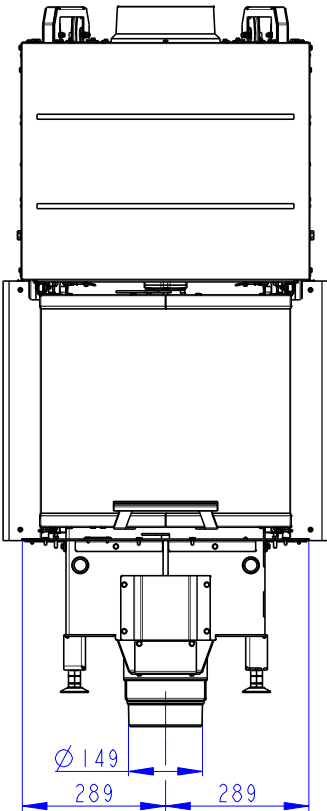

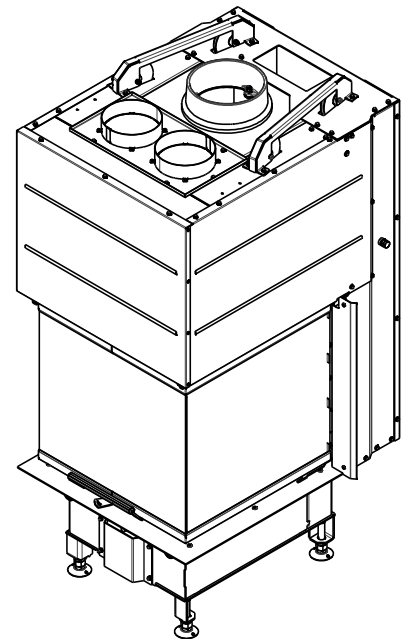

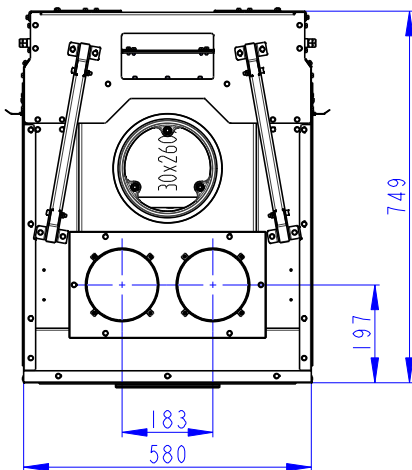
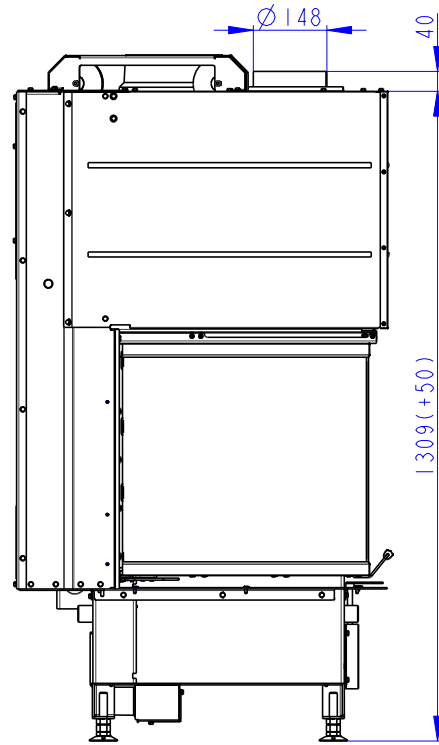
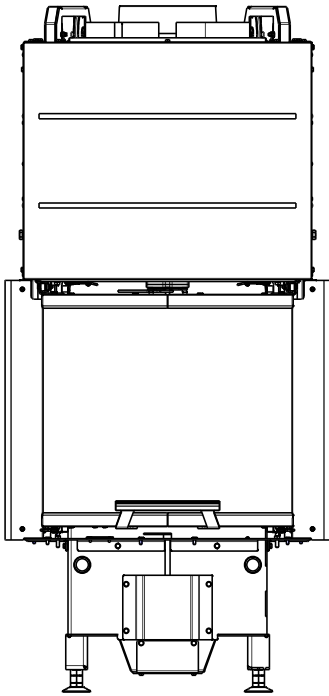
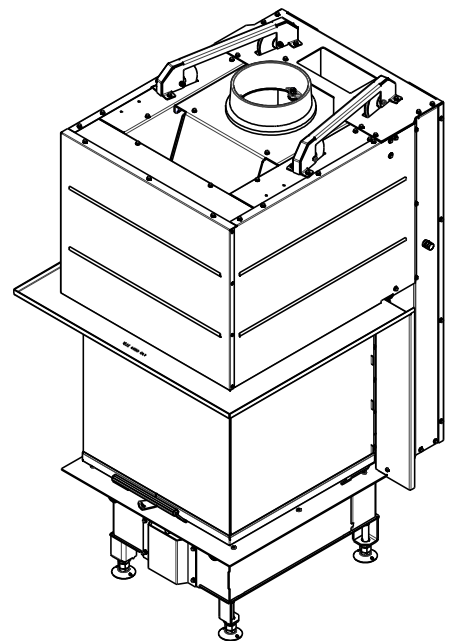
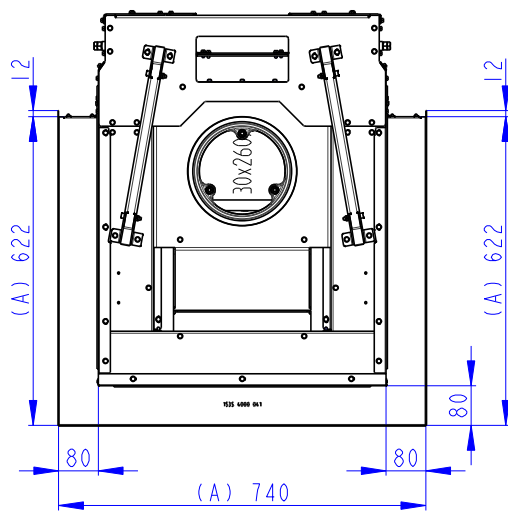
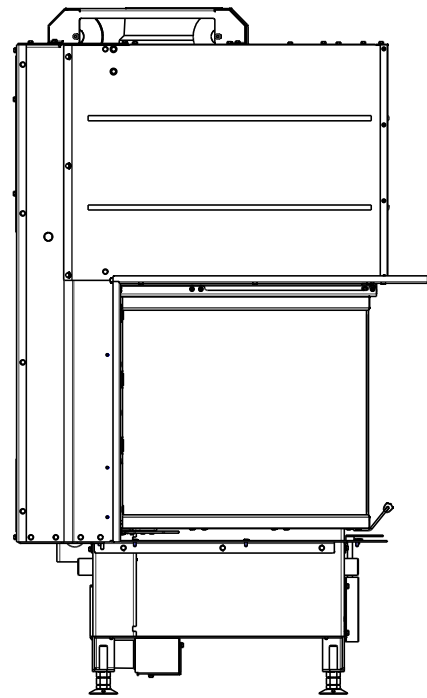
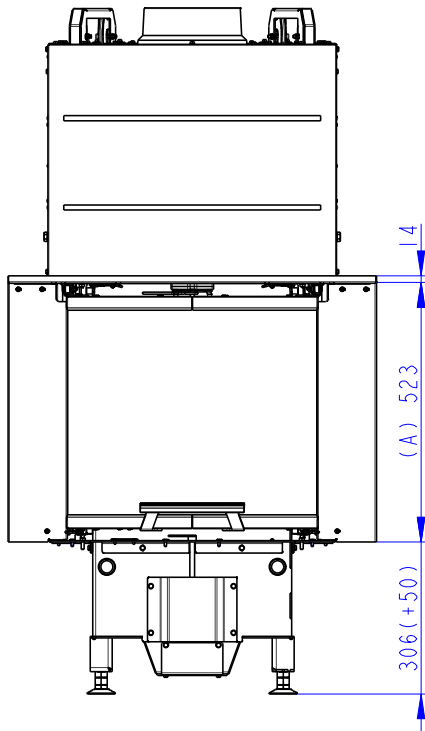
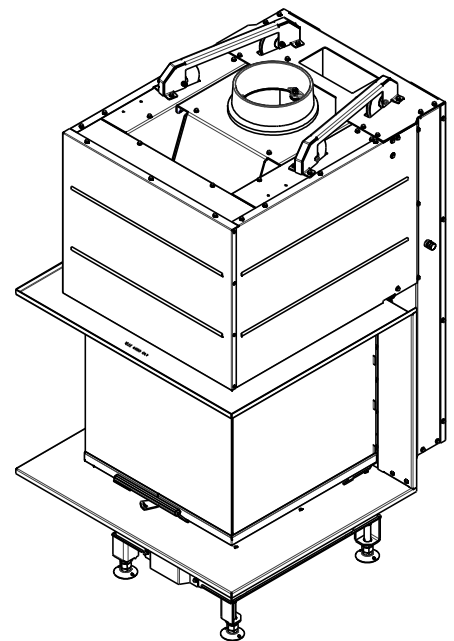
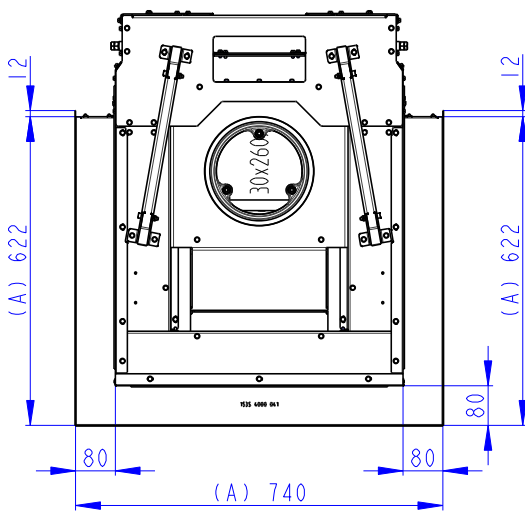
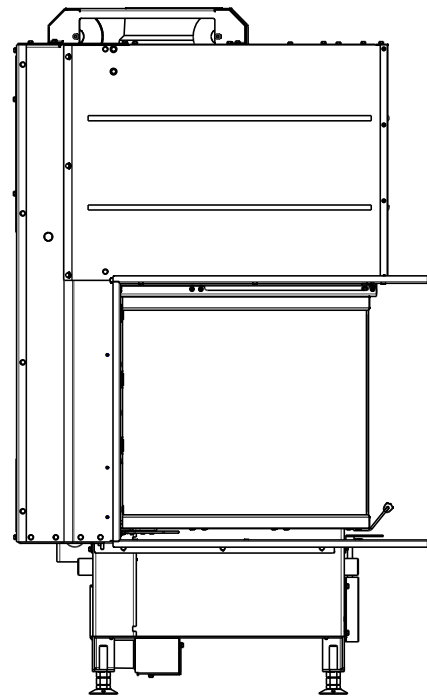
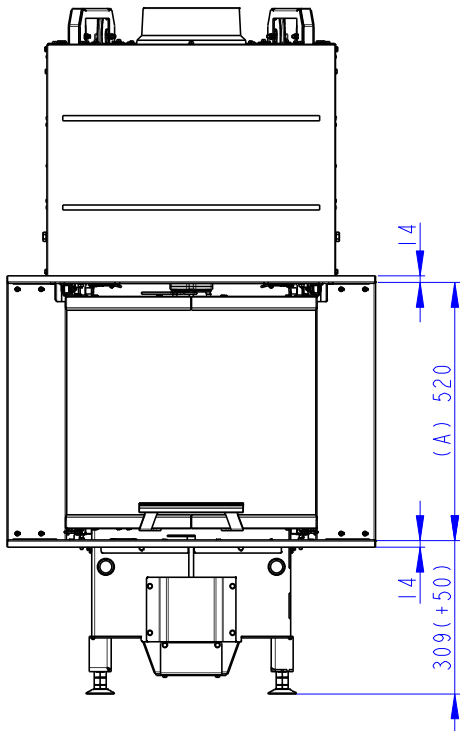

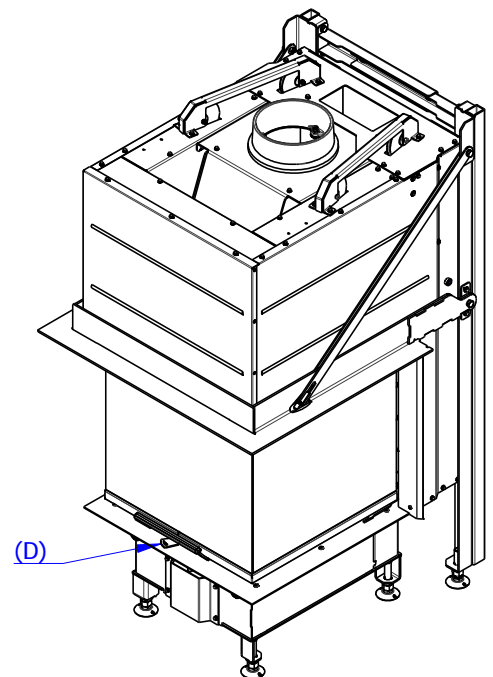
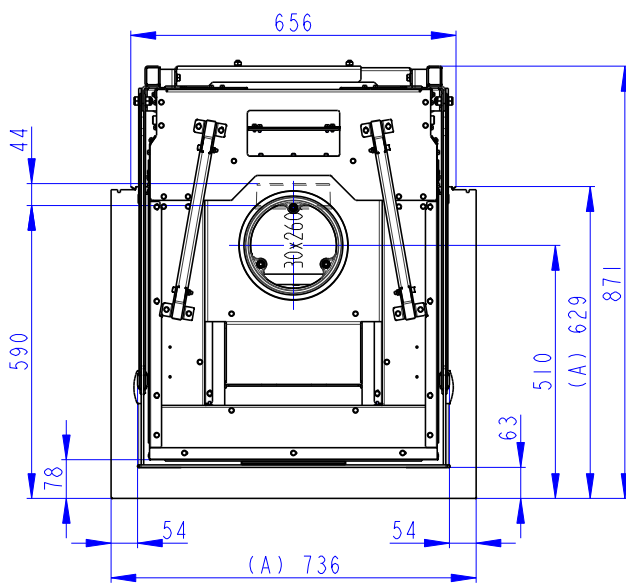
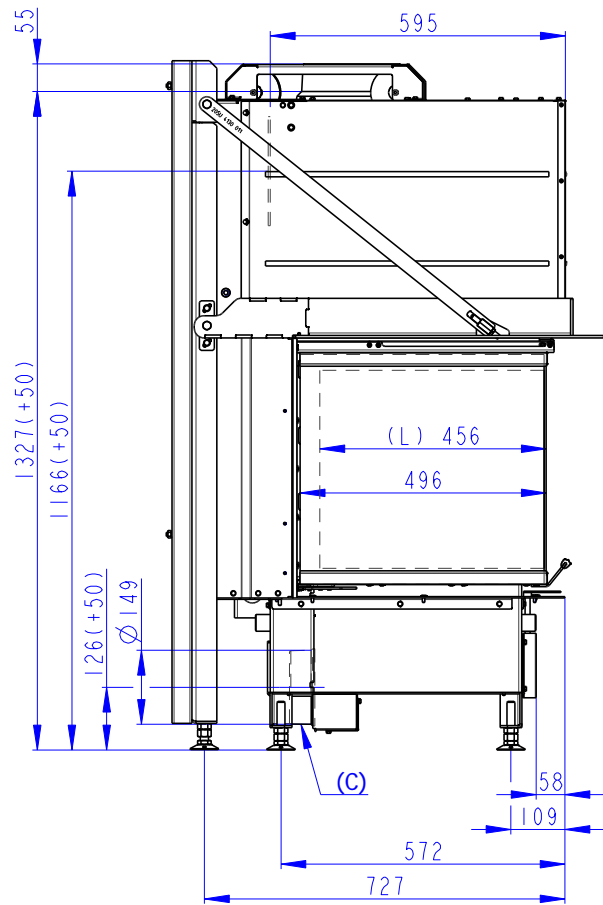
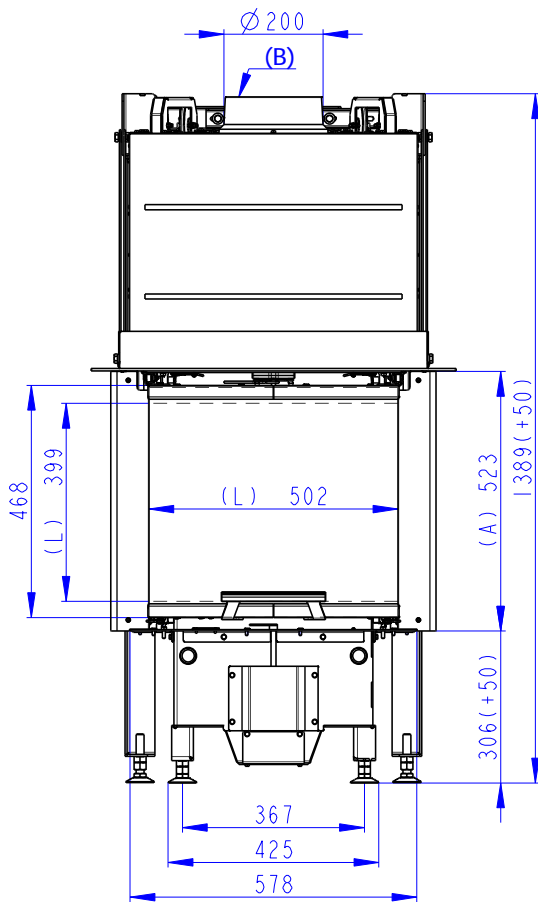

- (A) Zastavbovy rozmer / In-built dimension / Baumaße
- (B) Litinový odvod kouře / Cast iron spigot / Der gusseiserne Rauchabgang
- (C) Centralní privod vzduchu / Central air inlet / Zentralluftzufuhr
- (D) Primární a sekundární vzduch / Primary and secondary air / Primärluft und Sekundärluft
- (L) Volná plocha prosklení / Free glass area / Freie Glassichtfläche

